

# P2+BL PRO

## THE LEDTEK PRO LEAGUE

Simple design, easy and quick installation and out-standing quality: the LEDTEK PRO-series is a new generation of LED walls. The P4+WH PRO is now followed by the new P2+BL PRO, a professional indoor wall, particularly designed for demanding events inside.

The brilliant image and colour quality, a luminosity of 1,000 Nits and a pixel pitch of only 2.97mm guarantee a captivating result whose quality is shown to best advantage from a viewing distance of 3 metres. The roughly 16 million display colours contribute to the dynamic and lively display. All P2+BL PRO cabinets run with the A8s PRO receiving card (NovaStar). It offers functions like Full Grayscale Calibration, the Dynamic Booster and Image Boost to improve colour, contrast and brightness of the image reproduction. The colour fidelity is ensured through colour calibration.

The SMD 2020 LEDs make the wall particularly sturdy and hence suitable for the rental sector, where the walls will be set up and dismantled quite frequently. With the Tri-Frame, all kinds of installation options are possible. With the Tri-Frame studding e.g., constructions of up to 8m can be installed. Further options are the Tri-Frame base plate or the LED dolly. Static calculations are available for all versions.

The P2+BL PRO was subjected to a type test by TÜV Rheinland. Here, the fulfilment of all safety requirements was certified. To guarantee a steady quality, the entire production process at the manufacturing site, starting from the purchase of the parts to the outgoing goods is screened regularly by TÜV Rheinland.

The P2+BL PRO has also been tested for photobiological safety and electromagnetic compatibility and complies with the Low Voltage Directive. Of course, the P2+BL PRO is also covered by the 3-year LEDTEK warranty.

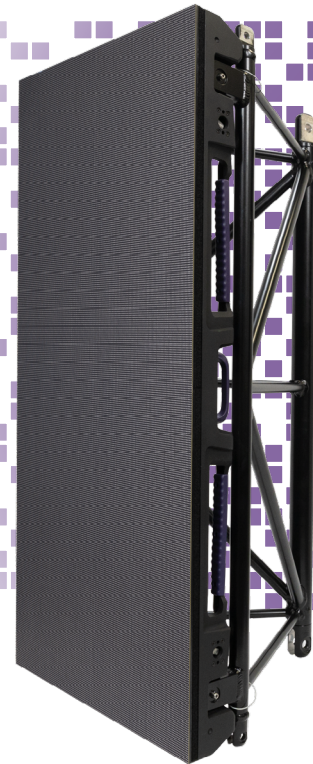

### Special features and advantages

- Brilliant image and colour quality
- Static proof and test book (EN-13814)
- Ubeatable cost/performance ratio
- Articles in stock
- Rental Pool
- 3-year LEDTEK guarantee
- More than 15 years of experience and know-how

### Certifications of the PRO-series

ROHS / CE

EMV Prüfbericht: AE50425582;

NSpRL Prüfbericht: AN50499148

PhotoBioSi Prüfbericht (EN-62471): R2DGG150318053-03M1

TÜV-Zertifizierung: ID 1111250394



Bauart geprüft  
Sicherheit  
Regelmäßige  
Produktions-  
überwachung



www.tuv.com  
ID 1111250394

## Cabinet size

### LEDTEK P2+BL PRO

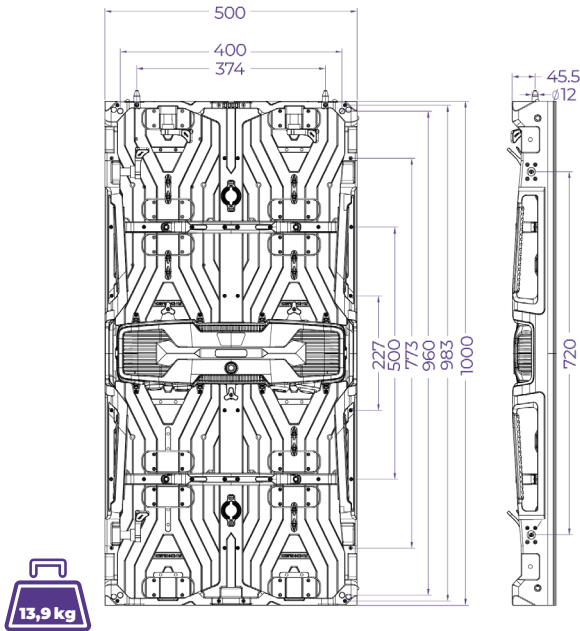

More at [ledtek.de/PRO\\_CAD.zip](http://ledtek.de/PRO_CAD.zip)

### LEDTEK P2+sBL PRO

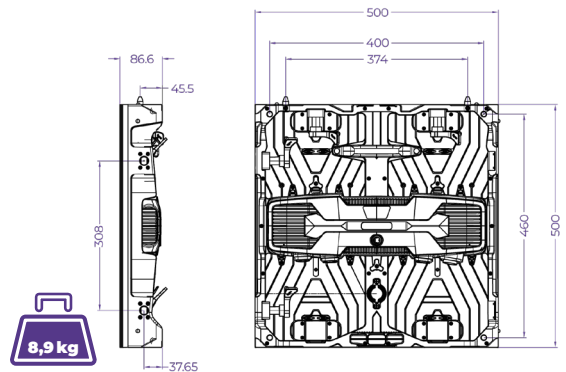

#### Cabinet features

Pixel pitch	2,97 mm
LED type	SMD 2020 (Kinglight)
SMD type (RGB)	(JT-KF0707QBZGSURM-BB-SI)
Resolution in pixel/m <sup>2</sup>	336 x 336px (BxH)
Number of pixel/m <sup>2</sup>	112,896 px/m <sup>2</sup>
Scanrate	1/21
Luminosity	1,000 Nits
Display colours	≥ 16 Mio
Contrast ratio	5,000:1
Refresh rate	3,840Hz (MBI 5253IC)
Receiving card	NovaStar A8s Pro
Power consumption	≤ 700 Watt/m <sup>2</sup>
IP code	IP 30
Horizontal	160°
Vertical	140°
Viewing distance	3m

#### Application areas

- Indoor events
- Fairs
- Presentations
- Concerts
- Suitable for rental sector

Scan for PRO-manual:



Scan for PRO-mediakit:



Further information and data (e.g. tender texts, user manuals, RCFGX-files) can be found at [www.ledtek.de](http://www.ledtek.de). If you have any questions, please contact us at +49 551 492493 44 or by email at [vertrieb@ledtek.de](mailto:vertrieb@ledtek.de).